

OPERATING INSTRUCTIONS

Electric screwdrivers

- TBe-Series -



TBe-Series:

TBe-1, TBe-5, TBe-10

TBe-1C, TBe-5C, TBe-10C

Issue date: August 2022

Table of contents

PAGE	3	1 Operating principles	
		1.1	Scope of delivery TBe-x - Series / TBe-xC - Series 3
		1.2	General information 5
		1.3	Signs and symbols used 6
		1.4	Structure of the warnings 6
		1.5	Technical terms and abbreviations used 7
		1.6	Intended use 7
		1.7	Improper use 8
		1.8	Duties of the operator 8
		1.9	Duties of personnel 8
		1.10	Training of personnel 9
		1.11	Guarantee and liability 9
		1.12	Copyright 9
PAGE	10	2 General safety information for power tools	
		2.1	Occupational safety 11
		2.2	Electrical safety 11
		2.3	Safety of people 12
		2.4	Use and handling of power tools 12
		2.5	Cleaning the Tool and disposal 13
PAGE	14	3 Start-up and use	
		3.1	Handheld Sensor Torque Drivers 15
		3.2	Technical data 15
		3.3	Putting the TBe-x - Series System into Operation 16
		3.3.1	Install the TBe-Manager Application 16
		3.3.2	Connect the Driver Cable to the Spindle and to the Power Supply 16
		3.3.3	Connect the Power Cord to the Wall Socket 17
		3.3.4	Connect the System to the PC via USB 17
		3.4	Putting the TBe-xC - Series System into Operation 17
		3.4.1	Install the TBe-Manager Application 18
		3.4.2	Connect the Driver Cable to the Spindle and to the TBe-TDC 18
		3.4.3	Connect the second Driver Cable to the TBe-TDC and to the Power Supply 18
		3.4.4	Connect the Power Cord to the Wall Socket 19
		3.4.5	Connect the TBe-TDC to the PC via USB or LAN 19
		3.5	Usage of the TBe-x - Series and TBe-xC - Series Systems 20
		3.5.1	Insert the Screw Bit 20
		3.5.2	Programming of the Screw Tightening Procedure 21
		3.5.3	Hand Button Function 21
PAGE	22	4 Torque Driver Communication Interface TBe-TDC	
PAGE	26	5 TBe-Manager Software Application	
PAGE	26	CE Declaration of conformity	

1 Operating principles

Dear customers,

thank you for choosing a HS-Technik GmbH product.

This quality product „Made in Germany“ fulfils the highest requirements with regard to performance, quality and accuracy. When used correctly the product will undoubtedly perform very well for many years.

These operating instructions contain information on safety and for the operation of the tool. In addition it contains information on the dimensions and technical data. We would be happy to assist you with additional information or to answer your questions. Our technical support and our technicians would be happy to assist you.

1.1 Scope of delivery TBe-x - Series / TBe-xC - Series

The typical scope of supply is the following:

- The TBe Spindle



- Operating instructions
- The Driver Cable (3 meters)



- The Power Supply TBe-PS-36-600



- The USB Cable



- The Windows-Application TBe-Manager



Attention:
TBe-Manager-Pro is a chargeable additional function,
only the TBe-Manager is included in the standard version.

- The Controller TBe-TDC*



- The Driver Cable (2 meters)*



* only available in the TBe-xC - Series version

1.2 General information

Read the operating instructions before initial operation. **Please pay particular attention to Chapter 2 „General Safety Notes“.**

This operating instruction should make it easier for the operator to get to know the tool and to use it for its intended purpose. The operating instructions include important information related to the safe and proper operation of the tool. Compliance with these instructions helps you to:

- Avoid hazards
- Avoid repair costs and downtimes
- Increase the reliability and the lifespan of the product.

This operating instructions must be read and applied by every person who is assigned to conduct work using this tool. Work on the electrical equipment may only be carried out by appropriately authorized persons.

In addition to these operation instructions the applicable regulations on accident prevention and environmental protection should be observed.







NOTE

After reading, keep the operating instructions in a place accessible to every operator. If you have any further questions, please feel free to contact us.

1.3 Signs and symbols used

The following signs and symbols will be used in this operating instruction or on the product:

Symbol	Explanation
	only use in closed rooms
	Read this operating instructions
	Do not dispose with household waste
	EU conformity marking

1.4 Structure of the warnings

The warnings are structured as follows:



DANGER

Indicates an immediate dangerous situation that can lead to serious or even deadly injuries and/or that could seriously damage or even destroy the tool.



WARNING

Indicates a potentially dangerous situation that can lead to serious injuries and/or damage to the tool.



NOTE

Important and useful information on using this tool.

1.5 Technical terms and abbreviations used

Abbreviation	Meaning
DC	Direct current
F.S.R.	full scale range

1.6 Intended use

The power tool you have was designed to make screw connections. The tool may only be used for this purpose as described in this operating instructions. Only materials that are suitable for this type of tool may be used.



WARNING

Intended use also includes

- following all indications of the operating instructions and
- observance of inspection and maintenance works.

Any other use or use beyond that is considered improper use. HS-Technik GmbH is not liable for any damage resulting from this.

1.7 Improper use



DANGER

The use of this tool for other purposes, e.g. for hammering, is not permitted. Improper use or incorrect accessories can lead to dangers with unforeseeable consequences.

We accept no liability for damage and malfunctions resulting from non-observance of these operating instructions and improper use.

1.8 Duties of the operator

The operator undertakes to only allow people who are familiar with the basic regulations on work safety and accident prevention and who have been trained on how to use the tool at the workplace and to work with this tool.

The safety awareness of the personnel while working has to be reviewed at regular intervals.

In addition it is necessary to define safety measures for operator protection which are based upon an estimation of the vibration load during actual conditions of use.

1.9 Duties of personnel

Prior to its use all people who work with this tool are obligated to inform themselves of the applicable workplace safety and accident prevention regulations for this power tool and to observe them. It is recommended that every operator wears hearing protection.

1.10 Training of personnel

Only trained and instructed personnel should work with this tool. The responsibilities of the personnel must be clearly defined. Trainees may only work with this power tool under the supervision of an experienced person.

1.11 Guarantee and liability

Guarantee and liability claims for personal injury and property damage are excluded, if caused by one or more of the following:

- improper use
- failure to observe these operating instructions
- improper installation, commissioning, operation and maintenance of the device
- Operating the device with defective safety devices or improperly installed, or non-functioning safety and protective devices
- Failure to observe the information in the operating instructions regarding transport, storage, assembly, commissioning, operation and maintenance of the device
- unauthorised structural modifications to the device
- improperly performed repairs
- catastrophes due to external influences and acts of God

1.12 Copyright

These operating instructions are intended solely for the operator and its personnel.

They contain guidelines and information which may not be fully, or partially

- reproduced
- distributed or
- otherwise shared.

The copyright of these operating instructions is retained by HS-Technik GmbH.

2 General safety information for power tools

DANGER



Read all the safety information, instructions, illustrations and technical data which is provided with this power tool. Failure to follow the instructions below may result in electric shock, fire and/or serious injury.

DANGER



Pay attention to the cycle time! There is a risk of overheating the screwdriver. The following is specified: 0.5 seconds "screwdriver on" and 3.5 seconds "screwdriver off" (rest time for cooling down).

WARNING



This power tool was manufactured in accordance with current state-of-the-art technology and recognised technological safety guidelines. However, its use may jeopardise the health and life of the user or third parties, or risk damage to other property.

WARNING



The workplace must only be used in accordance with its intended use and in technically perfect condition.

NOTE



Keep all safety information and instructions for the future.

NOTE



Only have your device repaired by qualified professional staff and only with original replacement parts which are available at HS Technik GmbH. This ensures that the safety of the device is maintained.

NOTE



Only use the power supplies or control units recommended by us. Only these control units comply with the CE standards EN 60204-1 / EN 61000-6-2.

2.1 Occupational safety

- a) **Keep your work area clean and well-lit.** Cluttered or dark work areas can lead to accidents.
- b) **Do not work with the power tool in an explosive environment in which there are flammable liquids, gases or dust.** Power tools generate sparks that can ignite the dust or fumes.
- c) **Keep children and other people away while using the power tool.** You can lose control of the power tool if you are distracted.

2.2 Electrical safety

- a) **Avoid body contact with grounded surfaces such as pipes, heaters, stoves and refrigerators.** There is an increased risk of electric shock if your body is grounded.
- b) **Keep power tools away from rain or moisture.** Penetration of water into a power tool increases the risk of electric shock.
- c) **Do not misuse the connection cable in order to carry, or hang up the tool, or to pull the plug out of the socket. Keep the connection cable away from heat, oil, sharp edges or moving parts.** Damaged or tangled connection cables increase the risk of electric shock.
- d) **Check the electrical equipment regularly. Immediately remove loose connections and scorched cables.** Loose connections or scorched cables can lead to electric shock and risk of fire.

2.3 Safety of people

- a) **Be alert, pay attention to what you are doing and take care when you are working with a power tool. Do not use a power tool when you are tired or under the influence of drugs, alcohol or medication.** A moment of inattention while using the power tool can result in serious injury.
- b) **Wear personal protective equipment and always safety glasses.** Wearing personal protective equipment such as a dust mask, non-slip safety shoes, safety helmet or hearing protection, depending on the type and use of the power tool, lowers the risk of injury.
- c) **Prevent accidental starting. Ensure that the power tool is switched off before you connect it to the power supply and/or the battery, pick it up or carry it.** Accidents can occur if you have your finger on the switch while carrying the power tool or if you connect the power tool to the power supply when it is switched on.
- d) **Avoid abnormal postures. Make sure you have a secure footing and keep your balance at all times.** This gives you better control of the power tool in unexpected situations.
- e) **Wear suitable clothing. Do not wear loose clothing or jewellery. Keep hair and clothing away from moving parts.** Loose clothing, jewellery or long hair can get caught in moving parts.
- f) **Do not lull yourself into a false sense of security and do not disregard the safety rules for power tools, even if you are familiar with the power tool after repeated use.** Careless action can lead to serious injuries within a split second.
- g) **Actively avoid accidentally switching on the power tool. If the tool is to be in idle mode for a long time, disconnect it from the Power Supply.** This prevents unintentional start-up.

2.4 Use and handling of power tools

- a) **Do not overload the power tool. Use the power tool specific for the work you are doing.** With the appropriate power tool you will work better and more safely in the power range indicated.
- b) **Do not use any power tool which has a defective switch.** A power tool which can no longer be switched on or off is dangerous and must be repaired.

- c) **Keep unused power tools out of the reach of children. Do not let anyone use the power tool who is not familiar with it or has not read this operating instructions.** Power tools are dangerous when used by inexperienced people.
- d) **Maintain power tools and the application tool with care. Check whether moving parts function properly and do not jam, whether parts are broken or damaged in such a way that the function of the power tool is affected. Have damaged parts repaired before using the power tool.** Many accidents are caused by poorly serviced power tools.
- e) **Keep the tool clean.** Carefully maintained tools jam less often and are easier to manage
- f) **Use power tools, application tools, etc. in accordance with these instructions. While doing so observe the work conditions and the activities to be performed.** The use of power tools for anything other than the intended application can lead to dangerous situations.
- g) **Keep handles and gripping surfaces dry, clean and free of oil and grease.** Slippery handles and gripping surfaces do not allow safe operation and control of the power tool in unforeseen situations.
- h) **Use the correct power tool.** Do not use under-performing tools for heavy loads. Do not use tools for purposes and work for which they are not intended.
- i) **Check your device for damage.** Before continued use of the tool safety equipment must be tested for proper and intended function. Check whether the function of moving parts is okay, whether they do not jam, whether any parts are broken, whether all other parts function properly and whether all conditions which must be met for the proper operation of the device have been met. Damaged protective devices and parts should be properly repaired, or replaced by trained customer service unless otherwise specified in this operating instructions. Damaged switches must be replaced by a customer service workshop. Do not use any tools which cannot be properly switched on and off using the start button.

2.5 Cleaning the Tool and disposal



The used substances and materials must be handled and disposed properly, especially when cleaning with solvents.

3 Start-up and use

DANGER

Risk of injury from damaged tools

Damaged tools can lead to injuries or damages.

- All damaged parts must be repaired before use.

Risk of injury from falling tools

Falling tools can lead to injuries or damages.

- Ensure you are self-belayed and have a secure footing.
- Avoid dropping the tool.



Risk of injury due to improper use

Improper use can lead to injuries or damage.

- Use the tool only for the intended purposes.

Risk of injury from substances

Substances such as lubricating oil and grease are flammable on the skin.

- Avoid contact with such substances.
- Should you still come into contact wash the affected area carefully.



NOTE

Maintain your tool with care. Follow the operating instructions during maintenance and cleaning. Keep the handle free of lubricants and dirt.



NOTE

Do not drop the tool, and do not let any other objects fall onto the tool. Protect it from impacts.



NOTE

Ensure that the tool does not come into contact with splashing water or oil.

3.1 Handheld Sensor Torque Drivers

The **TBe-x - Series / TBe-xC - Series** Transducerized Torque Drivers are foreseen to have an online connection to a PC running the software TBe-Manager via USB for Graphical Readouts, Data Documentation, and for System Configuration. Four screw tightening program sets can be saved directly in the tool. The system configuration including the calibration data is also saved permanently in the tool.

3.2 Technical data

TBe-x - Series / TBe-xC - Series Sensor Torque Driver System

Description	TBe-1 / TBe-1C	TBe-5 / TBe-5C	TBe-10 / TBe-10C
Torque Range	0,1 - 1,0 Nm	0,5 - 5,0 Nm	1,0 - 10,0 Nm
Torque Measurement Accuracy	1% of the F.S.R.	1% of the F.S.R.	1% of the F.S.R.
Angle Measurement Resolution	0.1 Degrees	0.1 Degrees	0.1 Degrees
RPM Range	50 to 1,300 RPM	50 to 600 RPM	20 to 400 RPM
Bit Drive	¼" Hexagon Bit Quick Chuck	¼" Hexagon Bit Quick Chuck	¼" Hexagon Bit Quick Chuck
Dimensions	279 x 42 x 36 mm	279 x 42 x 36 mm	335 x 48 x 40 mm
Weight	0.88 kg	0.88 kg	1.20 kg
Interface	USB / Digital communication to TBe-TDC		

3.3 Putting the TBe-x - Series System into Operation

To put the TBe-x - Series System into operation, please follow these steps:

3.3.1 Install the TBe-Manager Application

Install TBe-Manager on your PC System (running Windows 10).

Please refer to the Software Manual



3.3.2 Connect the Driver Cable to the Spindle and to the Power Supply



Make sure that the connectors are attached perfectly, and that the connector screws are tightened securely.

3.3.3 Connect the Power Cord to the Wall Socket



3.3.4 Connect the System to the PC via USB

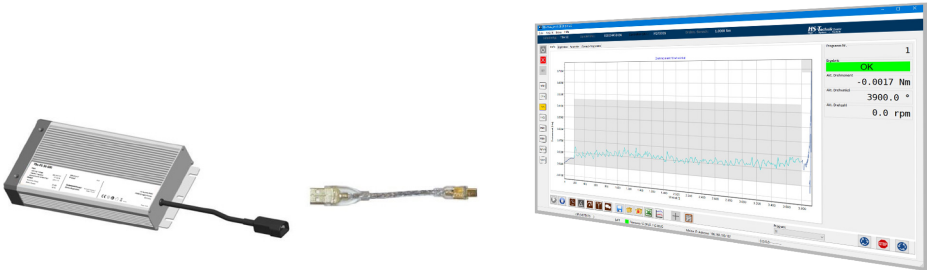

4 screw tightening program sets can be saved directly in the tool. The system configuration including the calibration data is also saved permanently in the tool.

3.4 Putting the TBe-xC - Series System into Operation

To put the TBe-xC - Series System into operation, please follow these steps:

3.4.1 Install the TBe-Manager Application

Install TBe-Manager on your PC System Windows 10. Please refer to the Software Manual

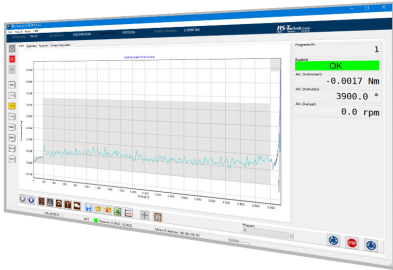

3.4.2 Connect the Driver Cable to the Spindle and to the TBe-TDC



Make sure that the connectors are attached perfectly, and that the connector screws are tightened securely.

3.4.3 Connect the second Driver Cable to the TBe-TDC and to the Power Supply



Make sure that the connectors are attached perfectly, and that the connector screws are tightened securely.

3.4.4 Connect the Power Cord to the Wall Socket



3.4.5 Connect the TBe-TDC to the PC via USB or LAN

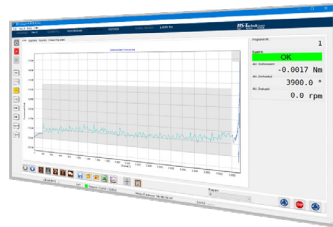

Up to 32 screw tightening program sets can be saved in the TBe-TDC. In case of an exchange, the programs must be downloaded to the PC, and reloaded to the exchanged device. Saving the programs regularly is recommended.

3.5 Usage of the TBe-x - Series and TBe-xC - Series Systems

3.5.1 Insert the Screw Bit

Use ¼" Hexagon Bits for the TBe-x - Series to TBe-xC - Series



Insert the Bit correctly while pushing the Chuck sleeve to the tip of the Spindle



3.5.2 Programming of the Screw Tightening Procedure

After Installation, please do the Screw Driver Programming according to the Screw Joint's requirements. Please refer to the TBe-Manager software programming Manual.

3.5.3 Hand Button Function

The reverse rotation can be programmed to a certain unscrew angle, or it can be configured to rotate as long as the button is being pressed. Please refer to the Software Manual.



4 Torque Driver Communication Interface TBe-TDC

Digital Interface Extension for Torque Driver Spindles **TBe-TDC**



Bestell-Nr.	Artikelbeschreibung
Memory	Storage for 32 screw tightening programs
Interfaces	12 opto-isolated digital inputs, NPN/PNP configurable, 24 V DC
	8 opto-isolated digital outputs NPN/PNP configurable, 24 V DC Connector Type: D-SUB-26-HD (female at the TBe-TDC)
	USB
	Ethernet Modbus-TCP
	RS-232-C (for Process Results only) Connector Type: D-SUB-9 (female at the TBe-TDC) Pinout: Pin-2: TxD Pin-3: RxD Pin-5: GND
Dimensions	105 x 84 x 46 mm
Weight	0.3 kg

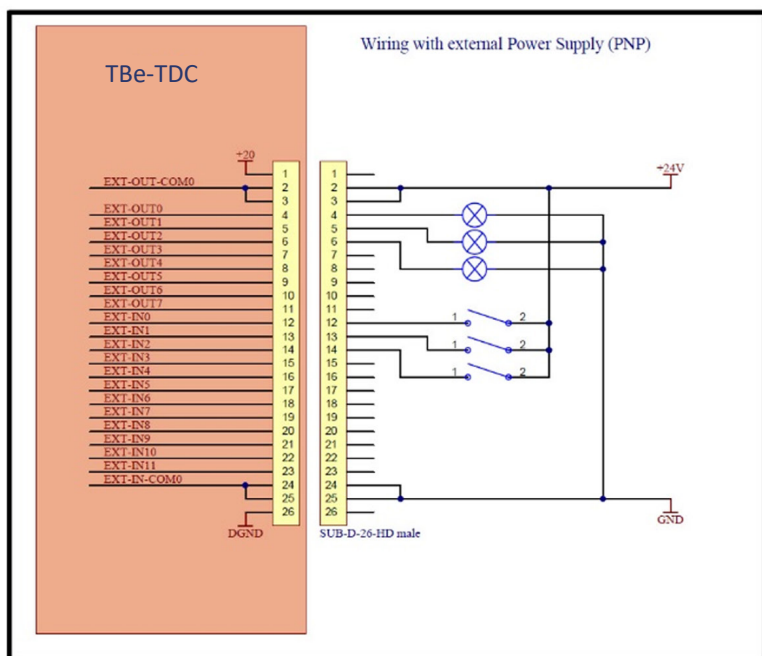
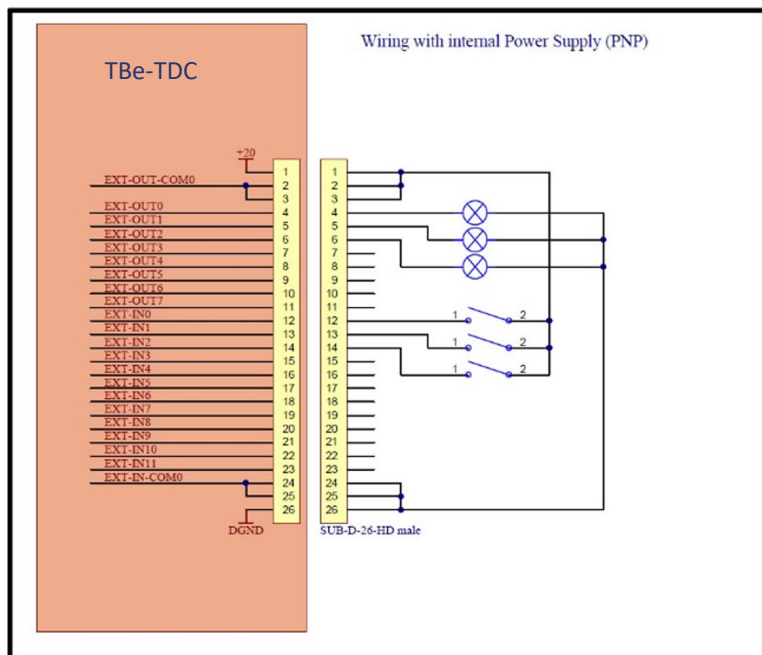

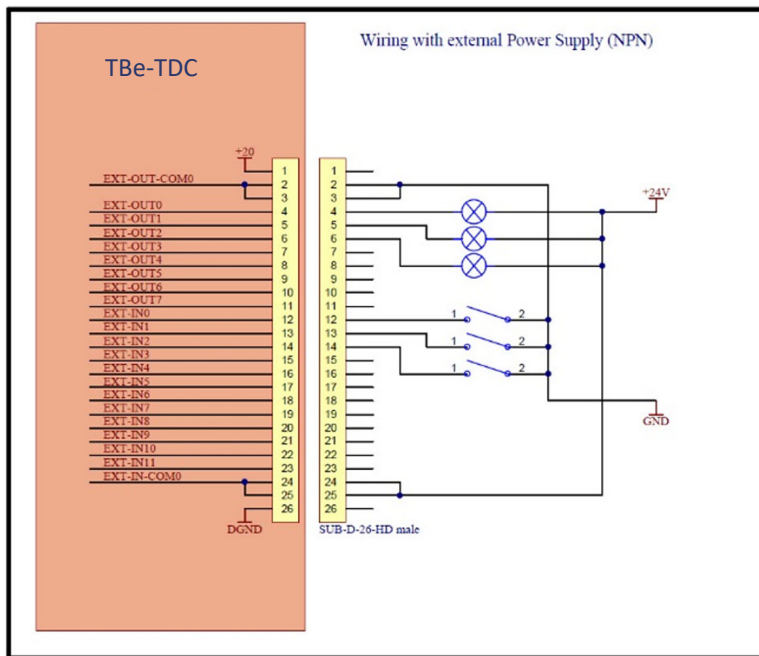

IO-List TBe-TDC V2.00.00

IN0:	Start
IN1:	Stop
IN2:	Unscrew
IN3:	PGM Bit0
IN4:	PGM Bit1
IN5:	PGM Bit2
IN6:	PGM Bit3
IN7:	PGM Bit4
IN8:	N/A
IN9:	N/A
IN10:	N/A
IN11:	Output Test
OUT0:	Busy
OUT1:	OK
OUT2:	Not OK
OUT3:	N/A
OUT4:	N/A
OUT5:	N/A
OUT6:	N/A
OUT7:	N/A

Programm Auswahl

B4	B3	B2	B1	B0	Program
0	0	0	0	0	1
0	0	0	0	1	2
0	0	0	1	0	3
0	0	0	1	1	4
0	0	1	0	0	5
0	0	1	0	1	6
0	0	1	1	0	7
0	0	1	1	1	8
0	1	0	0	0	9
0	1	0	0	1	10
0	1	0	1	0	11
0	1	0	1	1	12
0	1	1	0	0	13
0	1	1	0	1	14
0	1	1	1	0	15
0	1	1	1	1	16
1	0	0	0	0	17
1	0	0	0	1	18
1	0	0	1	0	19
1	0	0	1	1	20
1	0	1	0	0	21
1	0	1	0	1	22
1	0	1	1	0	23
1	0	1	1	1	24
1	1	0	0	0	25
1	1	0	0	1	26
1	1	0	1	0	27
1	1	0	1	1	28
1	1	1	0	0	29
1	1	1	0	1	30
1	1	1	1	0	31
1	1	1	1	1	32

TBe-TDC I/O-Timing Chart

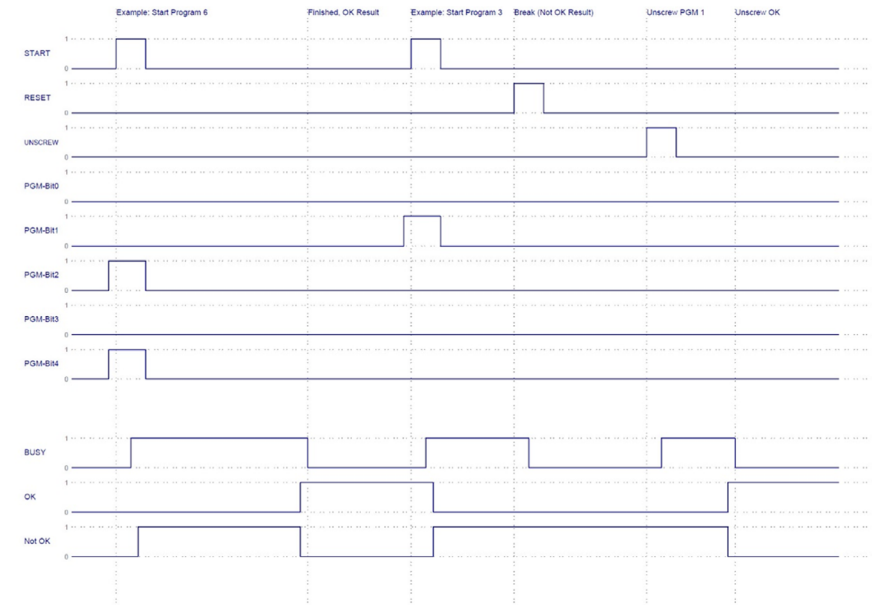

5 TBe-Manager Software Application

TBe-Manager is a software designed for TBe-x and TBe-xC Torque Driver parameter and program management, graphical visualization, and screw Driver process data logging. For details, please refer to the Software Manual.

CE Declaration of conformity

Sensor Torque Driver Series

Model selection	
TBe-1	TBe-1C
TBe-5	TBe-5C
TBe-10	TBe-10C

We, the manufacturer, hereby declare that the named tool complies with the essential protection requirements of the listed EU directives regarding design and construction type.

The prerequisite for this is the intended use of the tool as well as compliance with the installation and commissioning instructions.

If the product or its accessories are modified without our consent, this declaration becomes invalid.

Tool description:	Electric screwdriver
Type designation:	TBe-x TBe-xC
Manufacturer:	HS-Technik GmbH Im Martelacker 12 D-79588 Efringen-Kirchen
Directives:	2006/42/EG 2014/30/EU
Applied standards:	EN 60204-1: 2009 EN ISO 12100: 2010 EN 61000-6-1: 2007 EN 61000-6-2: 2005 EN 61000-6-3: 2007 + A1: 2011 EN 61000-6-4 + A1: 2011

HS-Technik GmbH
Im Martelacker 12, D-79588 Efringen-Kirchen

August 2022



Florian Hanke
CEO

HS-Technik GmbH
High - System - Technik

HS-Technik GmbH
Im Martelacker 12
D-79588 Efringen-Kirchen

Telephone: +49 (0)7628 - 91 11-0
Fax: +49 (0)7628 - 91 11-90
E-mail: info@hs-technik.com
Internet: www.hs-technik.com